

WOODCHIPPER TV 16-22



Powerful & robust "workhorse".
For chipping of twigs, branches &
stems of any type of wood with
maximum diameter of 160mm / 6,5".
Different models / versions available.



The TV16-22 is unique in its kind because :

- SIMPLE MAINTENANCE
- NO SHARPENING OF THE KNIVES REQUIRED!
- MEETS ALL **CE** SAFETY REGULATIONS
- OPTIMUM SAFETY
- SAFETY BAR SURROUNDING THE INFEED FUNNEL (VANDAELE[®] patent n° 2003/0590)

Features and benefits of the Vandaele wood chippers:

- Standard equipped with TUNGSTEN-CARBIDE knives and counter knives in sections.
- Sections are easily replaceable
- Renders sharpening and adjusting of the knives superfluous,
- Extreme long life span,
- Noise reduced knife disc, integrated in a wear resistant housing,
- Direct power linkages, no belts or chain drives,
- Robust construction, years of experience incorporated
- Very big capacity

Standard machine colour: RAL 2011 (safety colour)

Hundreds of references: contractors, councils & public services, etc...

Technical specifications:

TV16-22 ; Basic machine:

- Chipper disc ø 680 mm, equipped with 2 knives in CARBIDE TUNGSTEN,
- Counter knife in CARBIDE TUNGSTEN,
- 2 hydraulically driven infeed rolls with reverse coupling and chip size regulation from 1 to 25 mm,
- Infeed rolls powered trough tractor hydraulics (2 hoses with quick couplings),
- Ejector chute with adjustable flap: ± 2,3 m high, 300° revolving (EN 13525),
- Round wood diameter maximum: 160 mm / 6.5",
- Infeed opening between the rolls: 225 mm x 160 mm / 8.5" x 6.5",
- Noise reducing coating.



Hydraulic driven on self propelled tracked undercarriage



Hydraulic powered version for hydraulic tool carriers



360° revolving (option)

TV16-22 P ; tractor driven:

Standard:

Minimal required power = 25 HP,
PTO shaft speed = 1000 RPM,
3-point mounting system,
Free wheel PTO included

Optional:

Incorporated pump Group for powering of infeed rolls,
540 RPM reduction gearbox,
Anti-stress system,
Suspended trailer on wheels,
Long ejector chute (+1m),
Light bar on top of funnel

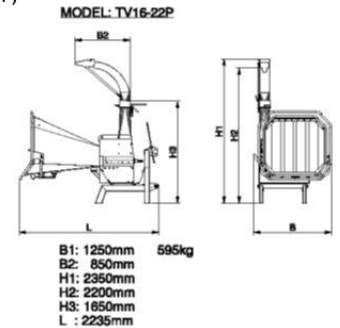

TV16-22 D ; diesel engine driven:

Standard:

Knife disc speed = 1500 RMP
HATZ diesel engine 52 HP, 3 cyl., air cooled,
Machine mounted on a galvanised road trailer, with mud guards and lights,
Fixed draw bar with ball hitch
Tires 185/14
Antistress system "Classic"

Optional:

Machine 360° revolving on a road trailer,
Transparent flaps in the funnel,
Extra noise dampening kit,
Long ejector chute (+1m),
Height adjustable drawbar with DIN eye or ball hitch,
Other RAL colour instead of RAL2011 & 7011

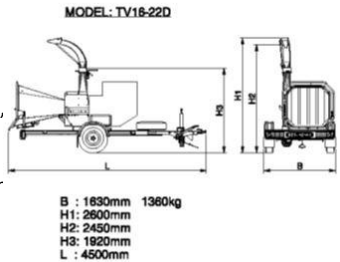

TV16-22 DATC ; engine driven on self-propelled tracked undercarriage

Standard:

Self-propelled hydraulic driven tracked undercarriage, on 360° turn table,
Foldable man platform with extra safety bracket,
Adjustable drive speed, forward and backwards driving,
"Deadman" control handles

Optional:

No man platform, remote control
Plastic flaps in the funnel,
Extra noise reduction kit,
Long ejector chute(+1m),
Studded top infeed roll,
Other RAL colour instead of RAL 2011 & 7011.

