

VANDAELE[®]
JUMBO MASTER



Vandaele® is a Belgian brand with deep roots dating back to 1966, founded by the Vandaele Brothers. Our history is steeped in a long tradition of machines for maintenance of green spaces and roadsides.

In 1992, an important step was taken by splitting the company due to a too large diversity of activities. This decision led to the founding of 'Vandaele Konstruktie,' an independent company with a focus on the Vandaele® brand, the construction of machines for green, forest and roadside maintenance.

- » **Experience:** at Vandaele® we have decades of experience in machines for green, forest and roadside maintenance. We have been committed to developing and producing high-quality machines since 1966.
- » **A strong brand with proven value:** Vandaele® is a premium brand known for its high residual value. Our machines are designed to last and retain their value, making a solid investment for your business.
- » **Craftsmanship:** Vandaele® is a Belgian manufacturer with a long history of machines for green spaces and roadside maintenance machines. Our craftsmanship is deeply rooted in our culture, and we are proud of the label "Made in Belgium." If you choose Vandaele®, you choose quality and reliability.
- » **Location:** With our presence in both Oostrozebeke and Ciney, including offices, a production department, service and repair workshops, and warehouses, we are strategically positioned to serve our global customers. Our international reach ensures swift parts delivery and efficient service, enabling seamless operations worldwide
- » **Customized constructions:** at Vandaele® we not only offer standard machines, but also custom-made constructions. We understand that your needs may be unique. Our team of experts work closely with you to create custom solutions that meet your specific requirements.
- » **Quality and certification:** We meet the highest quality standards, which is underlined by our ISO certification. In addition, we have European homologation for our trailers (COC).

**VANDAELE® OOSTROZEBEKE**

Stationsstraat 119
8780 Oostrozebeke

VANDAELE® CINEY

Zone industrielle
Rue du Fisine 11
5590 Ciney



MOWING SUCTION COMBINATION JUMBO MASTER

MOWING, COLLECTING AND TRANSPORTING - ALL IN ONE

Our mower suction combination is the perfect solution for slow transport, with three available capacity options: 25 m³, 30 m³ or 35 m³. At the front we have built a solid mowing arm and a super powerful turbine with an impressive reach of ± 5.70 meters (20 feet 4 inches). This arm is equipped with a double hydraulic safety.

JUMBO MASTER 25 m³ JUMBO MASTER 30 m³ JUMBO MASTER 35 m³



- » **Basic machine on heavy (2 x 9 tons) suspended tandem axle:** 22 tons
- » **Suitable for slow transport:** speed: 40 km/h, European C.O.C. homologation
- » **Fan: front-mounted heavy, wide fan, diameter:** 780 mm 31", driven at 1000 stainless steel with reinforced power band with 5 V-belts
- » **Hydraulic support foot:** hydraulically operated by the tractor hydraulics with shut-off valve
- » **Brake systems:** air brakes, air brake kit with valves must already be present on the tractor
- » **Optional coupling:** K80 ball coupling available instead of DIN towing eye 50 mm
- » **Spare wheel:** full-size spare wheel. Supplied loose or mounted in a mounting bracket.
- » **Colours:** personalized colors possible





SAFETY AND VISIBILITY - CLEAR SIGNAGE

Safety comes first, which is why the Jumbo Master is equipped with a series of safety features. Flashing lights, alternating flashlights lights and gradient lights (all LED technology) ensure that you are always clearly visible, even in the most challenging conditions. And with the built-in color camera on the back of the trailer, you always keep an eye on what's happening behind you.

- » **Lighting and signaling:** two LED flashing lights, alternating LED flash lights (diameter: 340 mm 13"), LED gradient light with 8 lamp blocks and 5 different operable menus in the cabin
- » **Optional extras:** extra LED lights set (rear, top), extra LED3 flashers, extra repeating LED rear lights, brake lights and indicators, separate control box in the cabin for all signaling
- » **Safety:** acoustic reversing signal > 100 dB(A) (must already be present on the tractor)



EASY OPERATION

The mowing suction combination is effortless to operate thanks to the electro-hydraulic proportional joystick control from the tractor cabin.

- » **Reversing camera:** 7" flat screen color monitor and sound in the cabin
- » **Control and maintenance:** large lockable control hatch along the right side, control window at the front





SELF-EMPTYING WITH EASE - SELF-UNLOADING WITH CHAIN SYSTEM

The Jumbo is designed to simplify your work. The self-unloading function with outwards turning floor chains makes emptying the wagon quick and easy.

The rear door is hydraulically operated at the back, giving you full control.



- » **Hydraulically operated rear door:** with built-in signaling sign (signaling sign: red-white striped) The signs includes also mandatory left-turn indications and cautionary symbols for roadworks (Ø 70 cm 28"), allowing customization to meet specific safety preferences and requirements.
- » **Self-unloading and bottom:** self-unloading with outward turning bottom, metal bottom plate, four reinforced bottom chains
- » **Hydraulic operation:** rear door and outward moving floor chains hydraulically operated with tractor hydraulics with separate distribution block at the rearside of the vehicle

DOUBLE-SIDED VERSATILITY:

Front mounted mowing suction arm, usable on both sides (left and right). Equipped with an overhead 1st cylinder for extra space above the fence Securely mounted on a heavy duty rotating cylinder for optimal stability

- » **Optional equipment:** hand suction hose (L= ± 5.00 m 197", Ø 200 mm 8") stainless steel suction nozzle with anti-stick suction edge. ALBZB300 leaf suction tube with hydraulically operated APD (Anti Prop Device), attached to the mowing arm instead of the flail mowing head, operated via the joystick. Suitable for litter and leaves in hard-to-reach places and for emptying leaf baskets.



SCOPE:

Right: ± 5.70 m (20 feet 4 inches) reach left: ± 4.70 m (185") reach with VD 1250 HD. Perfectly balanced from the center of the vehicle to the outside of the cutting head. The suction takes place in the auger bin behind the rotor; it is equipped with an auger that centers the cuttings, preventing direct suction on the ground

MOWING WORKING RANGE:

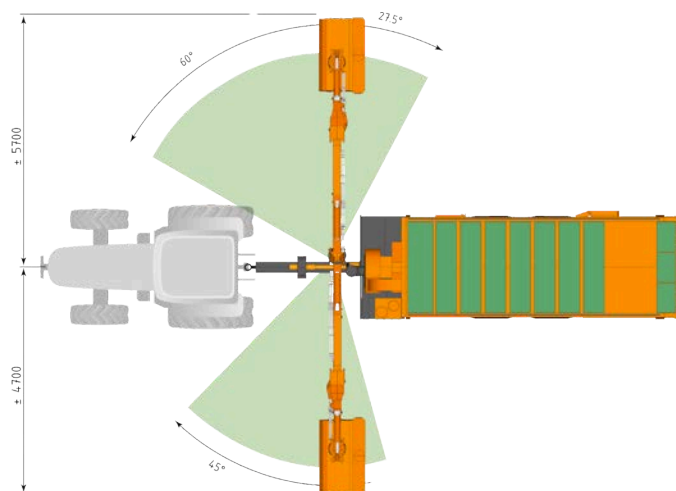

Specifications	<i>JS 25</i>	<i>JS 30</i>	<i>JS 35</i>
Trailer capacity m ³	25	30	35
Range in meter	R ± 5.70 (20 feet 4 inches)/ L ± 4.70 (185")		
Min. PTO power. (kW/hp)	100/135	110/150	115/155
Weight (kg)*	12.000	12.500	13.000
Take-off speed ratio (pto/tpm)	1000		
VD 165 J flails	Standard		

*Non-binding value

- » **Tyres:** type: 435/50R 19.5 Goodyear
- » **Optional storage options:** lockable plastic material case, Dimensions: W = ± 100 cm 39.5", H = ± 50 cm 19.7", D = ± 45 cm 17.7"



VD 165 J







VANDAELE[®]

CONTACT



+32 56 66 45 01



Stationsstraat 119, 8780 Oostrozebeke, Belgium



info@vandaele.biz



www.vandaele.biz

JUMBO MASTER
